



SANYO Semiconductors

DATA SHEET

LA3160 — Monolithic Linear IC For Car Stereo 2-Channel Preamplifier

Overview

The LA3160 is a 2-channel preamplifier for car stereo.

Features

- Two preamplifiers on chip.
- Fewer peripheral parts.
- Low noise.
- 8-pin SIP package facilitating easy mounting.

Specifications

Absolute Maximum Ratings at Ta = 25°C

Parameter	Symbol	Conditions	Ratings	Unit
Maximum supply voltage	V _{CC} max		18	V
Allowable power dissipation	Pd max		200	mW
Operating temperature	Topr		-20 to +75	°C
Storage temperature	Tstg		-40 to +125	°C

Recommended Operating Conditions at Ta = 25°C

Parameter	Symbol	Conditions	Ratings	Unit
Supply voltage	V _{CC}		9	V
Load resistance	R _L		10	kΩ

■ Any and all SANYO Semiconductor Co.,Ltd. products described or contained herein are, with regard to "standard application", intended for the use as general electronics equipment (home appliances, AV equipment, communication device, office equipment, industrial equipment etc.). The products mentioned herein shall not be intended for use for any "special application" (medical equipment whose purpose is to sustain life, aerospace instrument, nuclear control device, burning appliances, transportation machine, traffic signal system, safety equipment etc.) that shall require extremely high level of reliability and can directly threaten human lives in case of failure or malfunction of the product or may cause harm to human bodies, nor shall they grant any guarantee thereof. If you should intend to use our products for applications outside the standard applications of our customer who is considering such use and/or outside the scope of our intended standard applications, please consult with us prior to the intended use. If there is no consultation or inquiry before the intended use, our customer shall be solely responsible for the use.

■ Specifications of any and all SANYO Semiconductor Co.,Ltd. products described or contained herein stipulate the performance, characteristics, and functions of the described products in the independent state, and are not guarantees of the performance, characteristics, and functions of the described products as mounted in the customer's products or equipment. To verify symptoms and states that cannot be evaluated in an independent device, the customer should always evaluate and test devices mounted in the customer's products or equipment.

SANYO Semiconductor Co., Ltd.

TOKYO OFFICE Tokyo Bldg., 1-10, 1 Chome, Ueno, Taito-ku, TOKYO, 110-8534 JAPAN

LA3160

Electrical Characteristics at $T_a = 25^\circ\text{C}$, $V_{CC} = 9\text{V}$, $R_L = 10\text{k}\Omega$, $R_g = 600\Omega$, $f = 1\text{kHz}$, NAB

Parameter	Symbol	Conditions	Ratings			Unit
			min	typ	max	
Current dissipation	I_{CC}			4	6	mA
Voltage gain	VG	Closed loop		35		dB
		Open loop, $V_O = 0.77\text{V}$	76	80		dB
Output voltage	V_O	THD = 1%	1.1	1.8		V
Total harmonic distortion	THD	$V_O = 0.5\text{V}$		0.1	0.3	%
Input resistance	r_i		70	100		$\text{k}\Omega$
Equivalent input noise voltage	V_{NI}	$R_g = 2.2\text{k}\Omega$		1.25	2.0	μV
Crosstalk	CT		-50	-65		dB

Package Dimensions

unit : mm (typ)

3016C

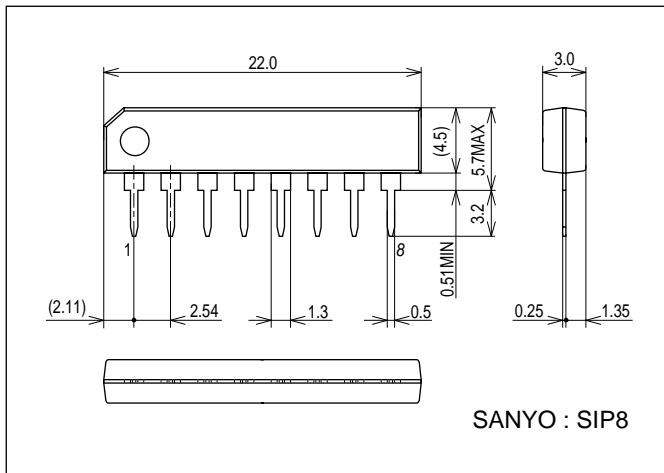

Equivalent Circuit

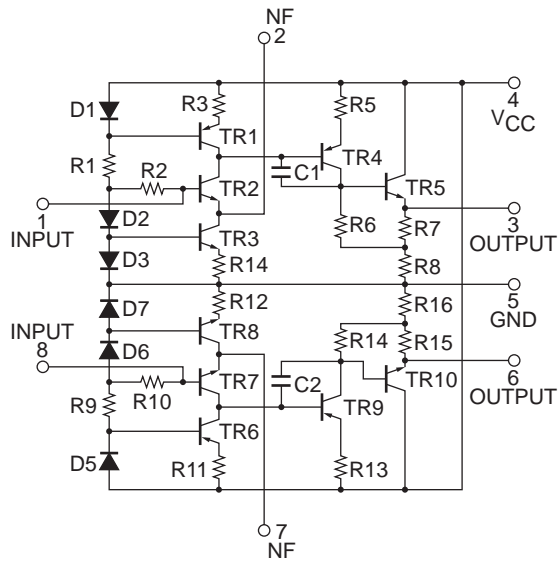

LA3160

Test Circuit 1 : V_O , V_G , THD, I_{CC} , r_i

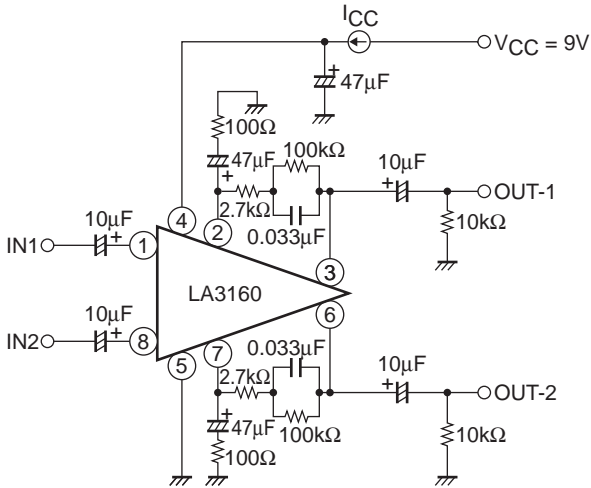

Test Circuit 2 : V_{G0}

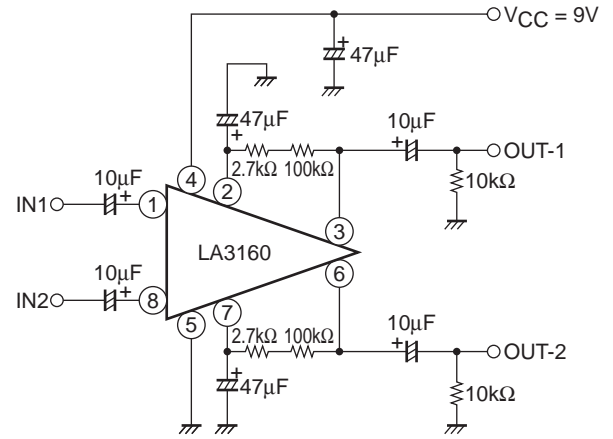

Test Circuit 3 : Noise

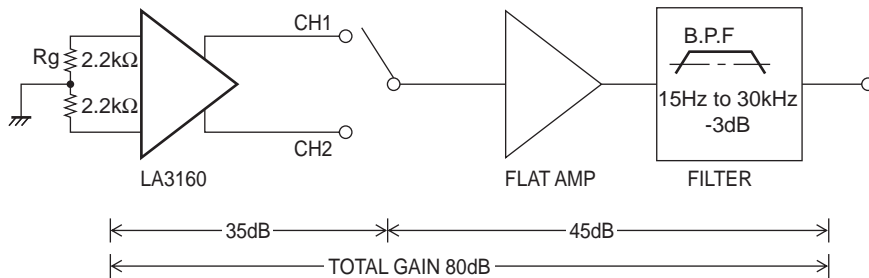

Application Circuit Example: Preamplifier for Car Stereo

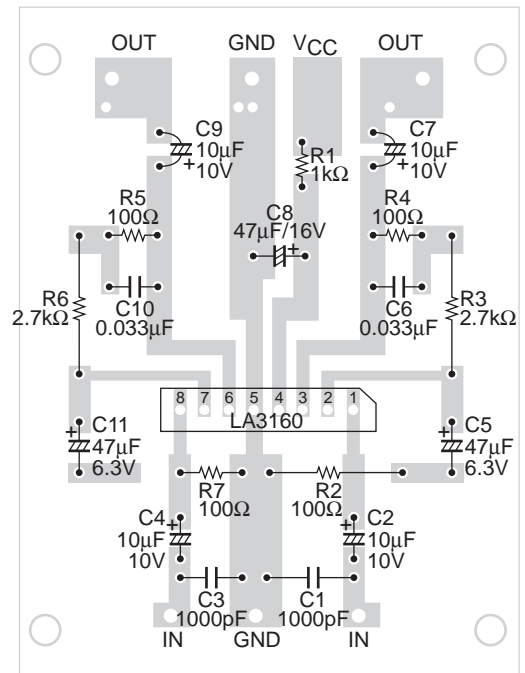
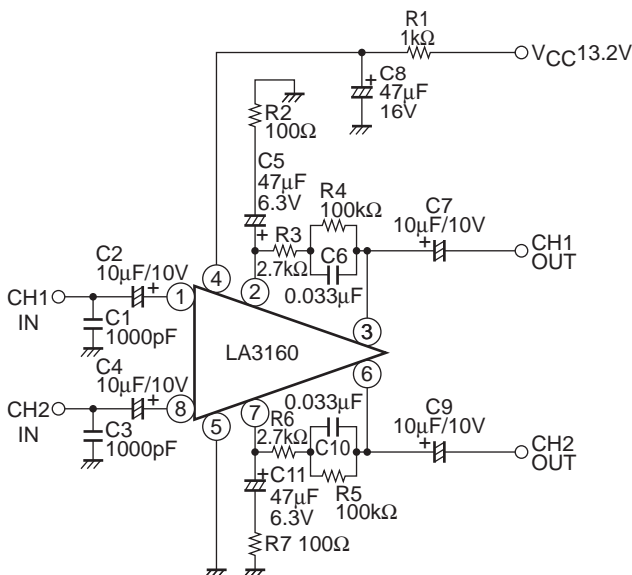

Sample Printed Circuit Pattern
(Cu-foiled area, 67×50mm²)

Function of External Parts

C2, C4 are input coupling capacitors. In NAB equalizer amplifier, the gain at low frequencies is high and 1/f noise inside the IC is emphasized as output noise. Therefore, if the reactance of capacitor at low frequencies is increased, the dependence of 1/f noise on the signal source resistance causes the output noise voltage to deteriorate, and the value of reactance must be made small enough as compared with the signal source resistance. C2, C4 also influence the operation start time and the adequate value of these capacitors is 10μF. (Since C2, C4 of less than 4.7μF make the operation start time longer, use C2, C4 of 4.7μF or more).

C5, C11 are NF capacitors. The lower cut-off frequency depends on the value of these capacitors.

If the lower cut-off frequency is taken as f_L :

$$C5 (C11) = 1/2\pi \times f_L \times R2 (R7)$$

If the value of this capacitor is made larger, the operation start time of amplifier is more delayed. The adequate value of capacitor is 47μF.

The frequency characteristic of the equalizer amplifier depends on C6 and R4, R3 (C10 and R5, R6).

The time constants to obtain the standard NAB characteristic are as shown below.

Tepe speed	9.5cm/s	4.75cm/s
C6 (R3+R4)	3180μs	1590μs
R3 C6	90μs	120μs

C8 is bias capacitor for the power line. C8 of 47μF is inserted at a point as close to the power supply pin (pin 4) as possible.

C1, C3 are for preventing radio interference in the strong electric field, interference attributable to engine noise, and blocking oscillation at the time of large amplitude operation. The adequate value of C1, C3 is approximately 1000pF.

C7, C9 are output coupling capacitors. The adequate value of C7, C9 is 10μF.

NAB element and determination of gain

Since the DC feedback is provided by R1, R2 of NAB element, which brings about DC output potential at pins 3, 6, it is impossible to change the value of R1, R2 of NAB element greatly. Therefore, when determining the gain, change R_{NF} with R1, R2, C1 (NAB element) kept constant.

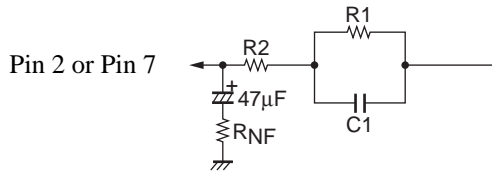

(1) How to obtain R_{NF}

Impedance Z of NAB element is

$$Z = \frac{1}{1/R1 + j\omega C1} + R2$$

$$= (R1 + R2) \left\{ \frac{1 + j\omega C1 \{R1 R2 / (R1 + R2)\}}{1 + j\omega C1} \right\}$$

For a general negative feedback amplifier circuit, $A = A_o / (1 + A_o\beta)$ applies, and $Z = A \cdot R_{NF}$ is obtained under conditions of $A_o \gg A$, $A \gg 1$ ($\beta = R_{NF} / (R_{NF} + Z)$, A_o = open-loop gain, A = feedback gain).

Therefore, we can use an approximation of $R_{NF} = Z/A$.

A = (VG for 1kHz) times, (Set R1, R2 at approximately 100kΩ)

Each time constant of NAB characteristic.

	Tepe speed	9.5cm/s	4.75cm/s
T1	C1, R1	3180μs	1590μs
T2	C1 (R1//R2)	90μs	120μs

(2) Examples of NAB Constants

(a) Tape speed : 9.5cm/s for an 8-track recorder (Z, AG : at f = 1kHz)

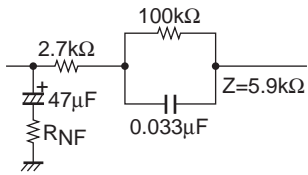

VG	30	35	40	dB
R _{NF}	180	100	56	Ω

(b) Tape speed : 4.75cm/s for a cassette tape recorder

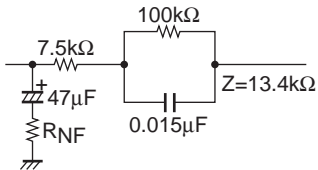

VG	30	35	40	dB
R _{NF}	440	240	130	Ω

(c) Flat amplifier

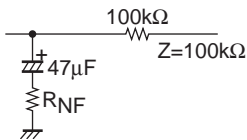

VG	30	35	40	dB
R _{NF}	3.2k	1.8k	1k	Ω

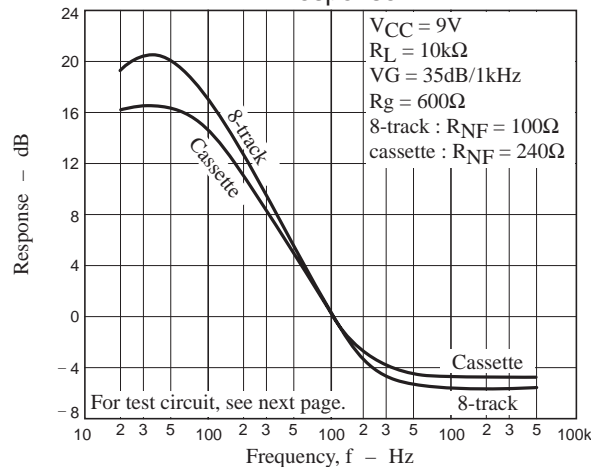
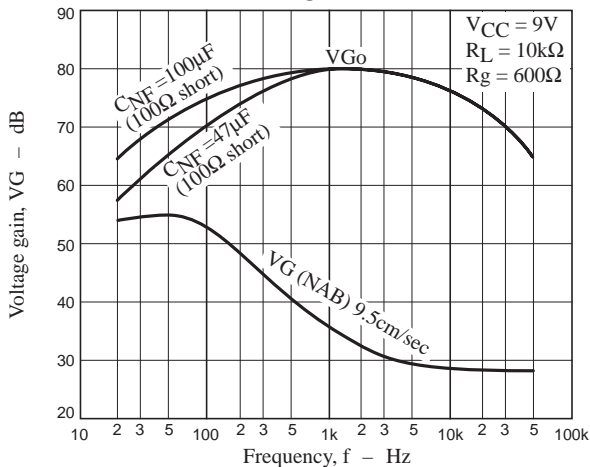
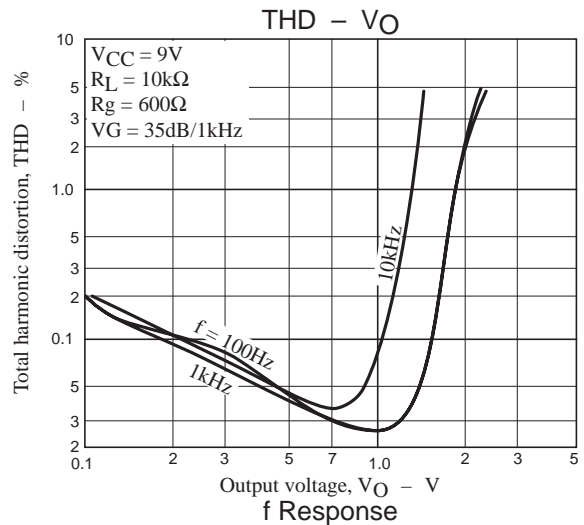
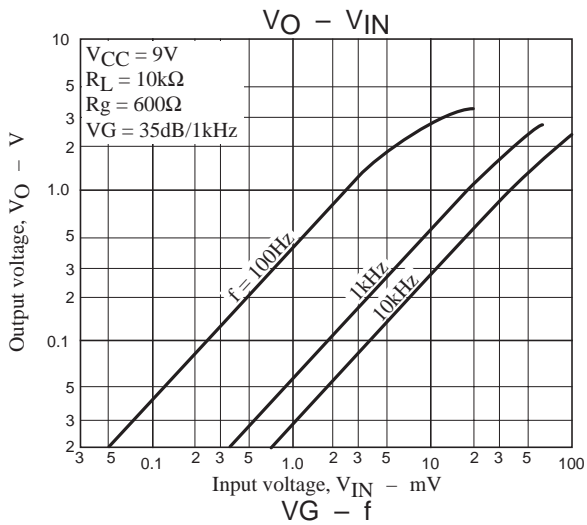

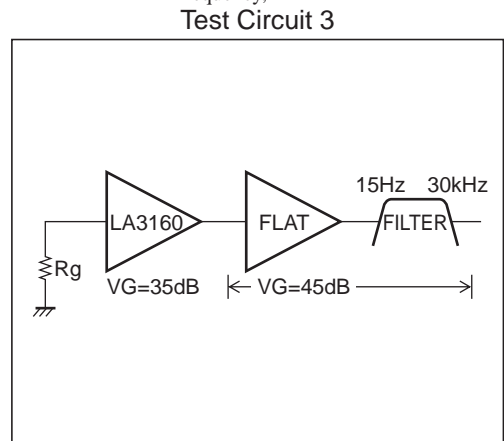
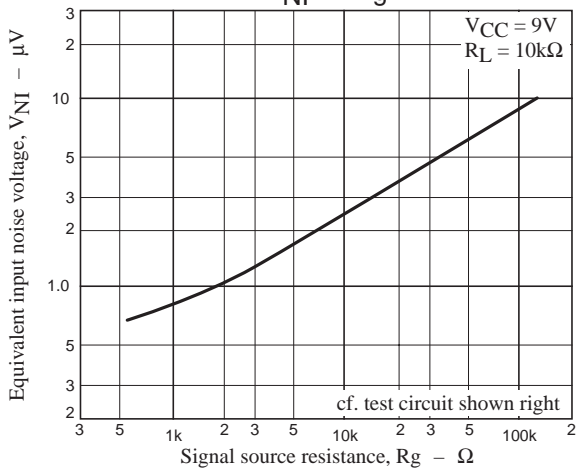
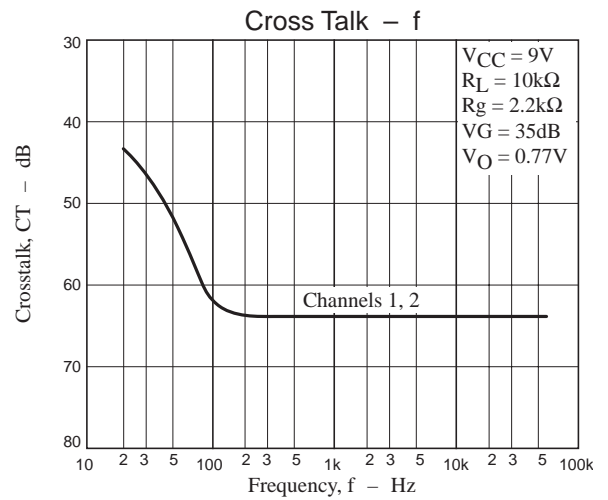
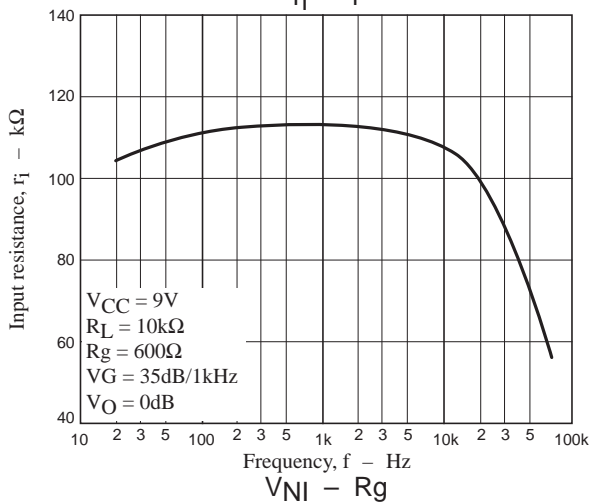
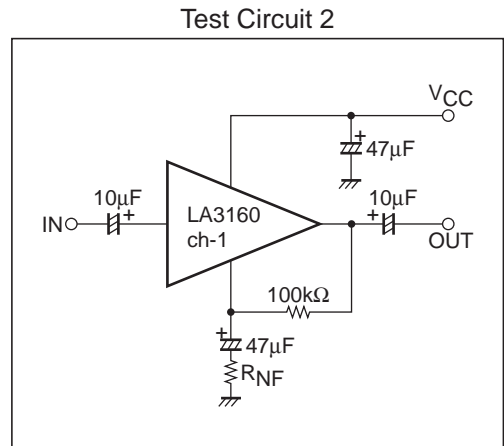
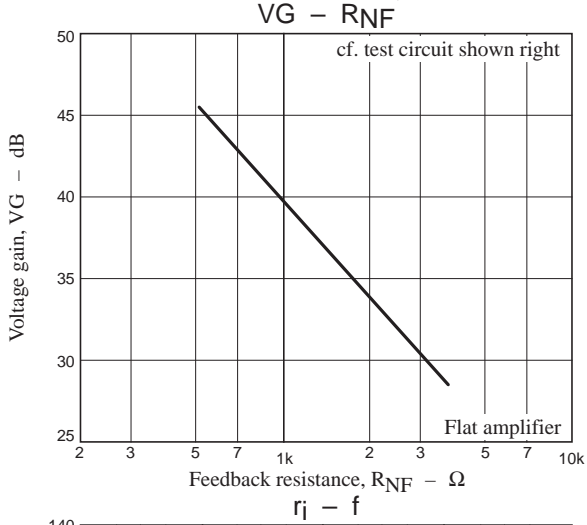
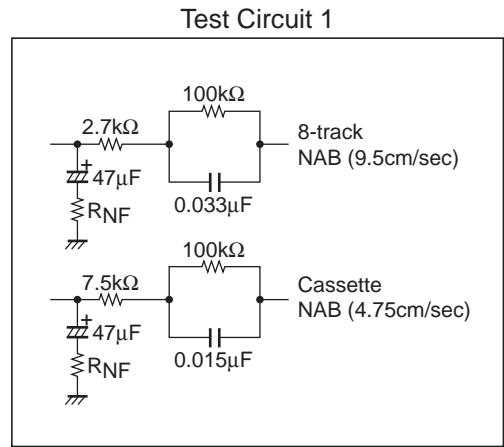
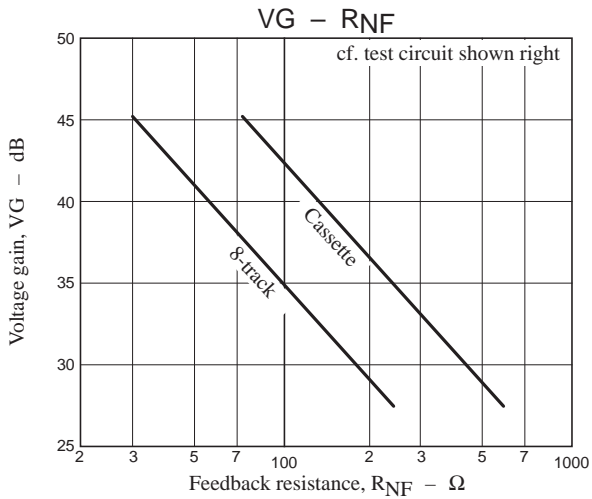

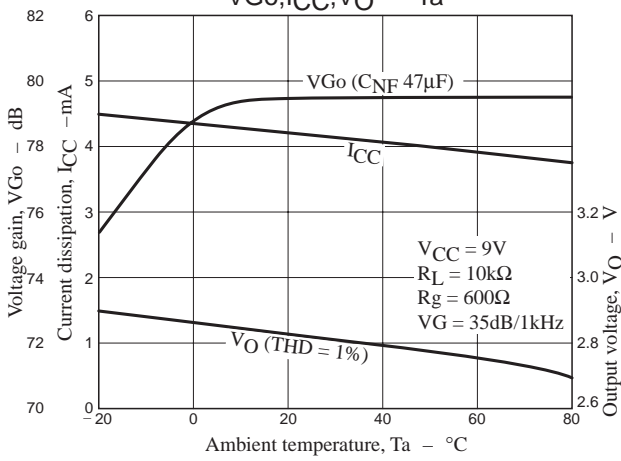
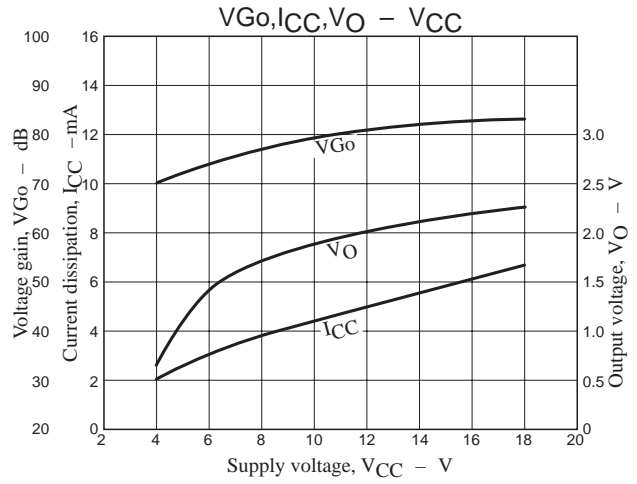
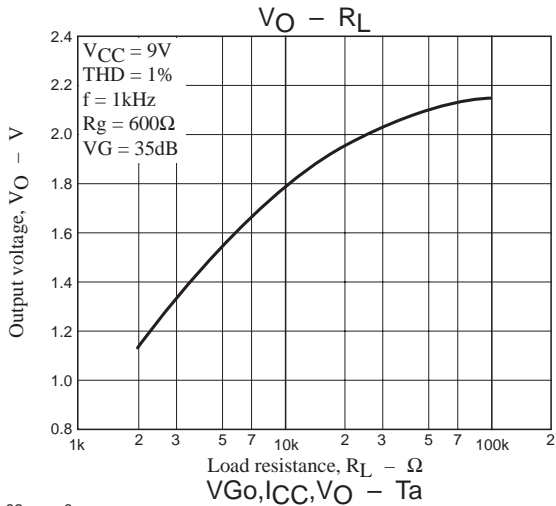

Proper cares in using IC

1. Maximum Rating

If the IC is used in the vicinity of the maximum rating, even a slight variation in conditions may cause the maximum rating to be exceeded, thereby leading to a breakdown. Allow an ample margin of variation for supply voltage, etc. and use the IC in the range where the maximum rating is not exceed.

2. Short between pins

If the supply voltage is applied when the space between pins is shorted, a breakdown or deterioration may occur. When installing the IC on the board or applying the supply voltage, make sure that the space between pins is not shorted with solder, etc.

3. Breakdown of IC attributable to inverted insertion

If the IC is inserted inversely and operated, the IC may suffer from something unusual, thereby leading to a breakdown or deterioration of the IC. When installing the IC on the board or operating the IC, check the marked surface of IC.

Proper cares to be taken for obtaining optimum operation of IC

- Set DC resistance of R1, R2 of NAB element at approximately 100kΩ.
- Determine the gain by changing RNF without chaging NAB constant (Refer to Examples of NAB constant.).
- Supply voltage characteristics are sufficiently considered, but supply voltage is recommended to be between 5V to 18V.

- SANYO Semiconductor Co.,Ltd. assumes no responsibility for equipment failures that result from using products at values that exceed, even momentarily, rated values (such as maximum ratings, operating condition ranges, or other parameters) listed in products specifications of any and all SANYO Semiconductor Co.,Ltd. products described or contained herein.
- SANYO Semiconductor Co.,Ltd. strives to supply high-quality high-reliability products, however, any and all semiconductor products fail or malfunction with some probability. It is possible that these probabilistic failures or malfunction could give rise to accidents or events that could endanger human lives, trouble that could give rise to smoke or fire, or accidents that could cause damage to other property. When designing equipment, adopt safety measures so that these kinds of accidents or events cannot occur. Such measures include but are not limited to protective circuits and error prevention circuits for safe design, redundant design, and structural design.
- In the event that any or all SANYO Semiconductor Co.,Ltd. products described or contained herein are controlled under any of applicable local export control laws and regulations, such products may require the export license from the authorities concerned in accordance with the above law.
- No part of this publication may be reproduced or transmitted in any form or by any means, electronic or mechanical, including photocopying and recording, or any information storage or retrieval system, or otherwise, without the prior written consent of SANYO Semiconductor Co.,Ltd.
- Any and all information described or contained herein are subject to change without notice due to product/technology improvement, etc. When designing equipment, refer to the "Delivery Specification" for the SANYO Semiconductor Co.,Ltd. product that you intend to use.
- Information (including circuit diagrams and circuit parameters) herein is for example only; it is not guaranteed for volume production.
- Upon using the technical information or products described herein, neither warranty nor license shall be granted with regard to intellectual property rights or any other rights of SANYO Semiconductor Co.,Ltd. or any third party. SANYO Semiconductor Co.,Ltd. shall not be liable for any claim or suits with regard to a third party's intellectual property rights which has resulted from the use of the technical information and products mentioned above.

This catalog provides information as of April, 2008. Specifications and information herein are subject to change without notice.